

# APE HOLLAND

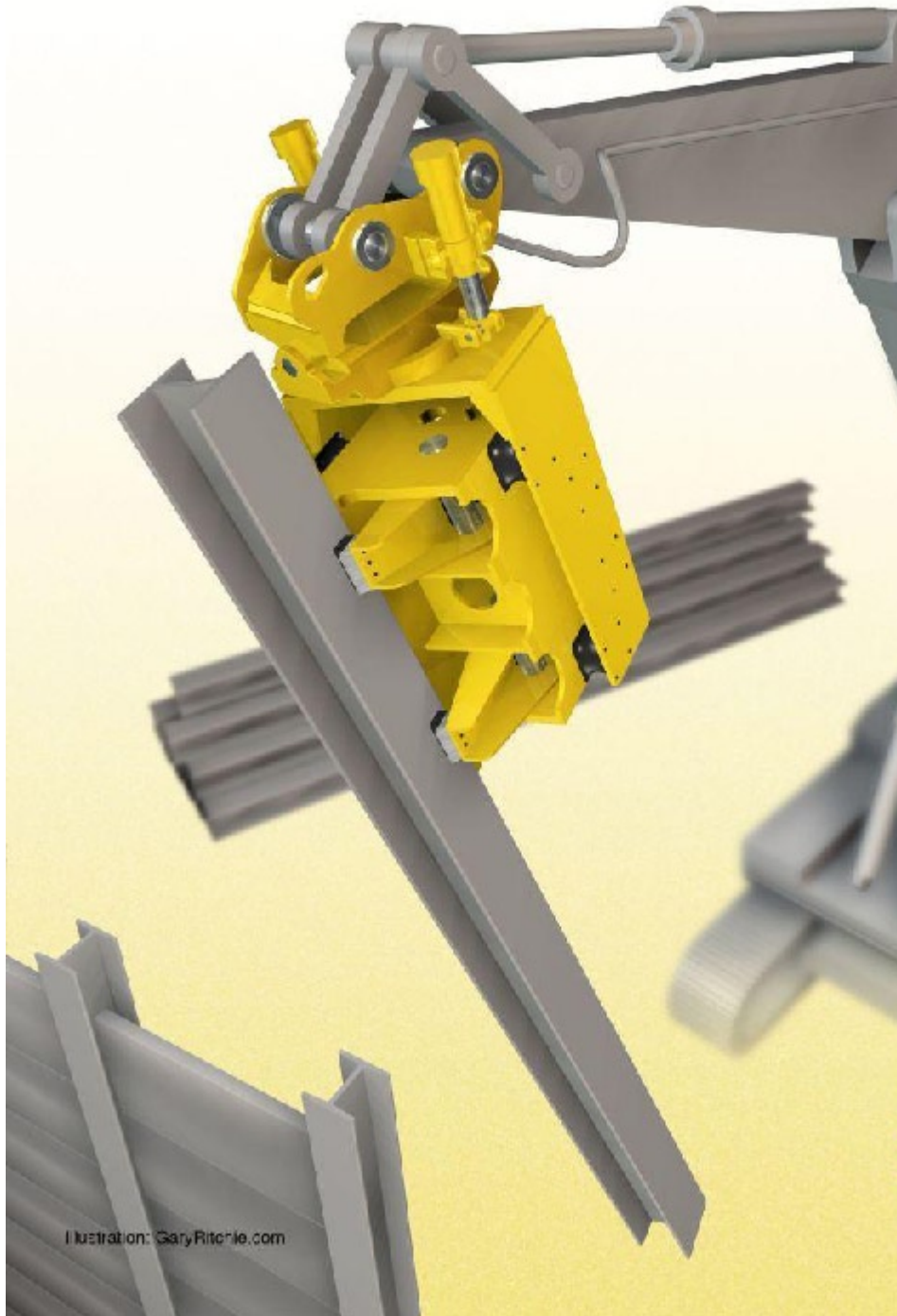
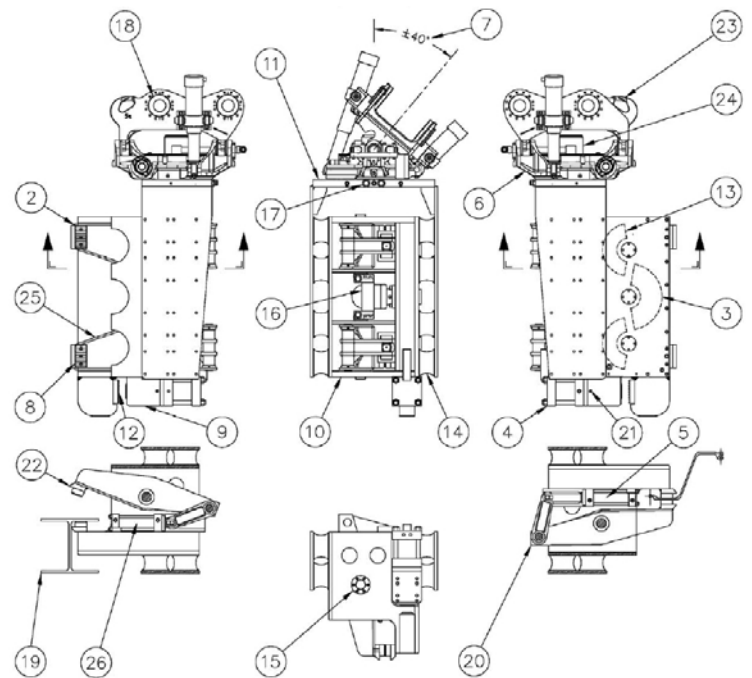
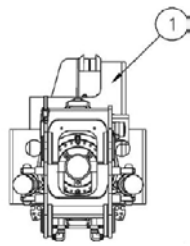

Illustration: Gary Ritchie.com

**ROBOVIB™**  
BETTER BY DESIGN

APE Holland BV, P.O. Box 34, 7990 AA Dwingeloo, The Netherlands  
Tel.: +31(0) 593 54 08 91, Fax: +31(0) 593 54 27 84, [www.apeholland.com](http://www.apeholland.com), [info@apeholland.com](mailto:info@apeholland.com)



Weight	2.085 kg
Moment	5,5 kg-m
Frequency	2.500 vpm
Dynamic force	382 kN (39 ton)
Amplitude	8 mm
Max. flow	360 lpm
Max. pressure	275 bar
Min. excavator	20 tons

### RoboVib - Not just better, Exceptional

1. The **RoboVib** eccentrics are located within the fixed, side grip, arm. Centerline of dynamic force is much closer to the gripping jaws, thus significantly reducing off center force input to the Pile. So, **Robovib** gets more driving energy to the tip of the pile.
2. Vertical distance between side grip jaws is increased to better resist off center, moment, load caused by both dynamic force and excavator force, which also equates to ability to resist off center force.
3. **RoboVib** eccentric moment is 22% greater than competitive units, producing significantly larger driving amplitude.
4. Both side grip clamp arms, and the bottom clamp, each have an individual actuating cylinder.
5. Side grip actuation cylinders are rigid mounted to transmission case, thus eliminating horizontal, pin mounted cylinders, which are subject to vibration damage. **RoboVib** cylinder rods are fully guided by rollers and actuate the clamp arms via force enhancing linkage.
6. Proven tilt and rotate mechanism is designed for digging duty and has sealed lubrication for bearings and worm gear. Cast housing and integral rotation motor maintain perfect alignment for worm gear and massive rotation bearing. Dual tilt cylinders are telescopic, providing lower profile and equal left and right tilt torque.
7. **RoboVib**  $\pm 40^\circ$  tilt is 33% more than the competition. Increased tilt allows additional left/right reach when loading or unloading piles.
8. Rectangular clamp jaws, on side grips provide more clamping area than round jaws.
9. Bottom clamp uses precision guided slider per accepted vibratory hammer practice. Clamp cylinder is directly aligned with the fixed jaw - no offset.
10. Most components contained within welded steel frame for protection and exceptional strength.
11. No solenoid valves or wiring mounted on **RoboVib**. Valves and wiring are remotely mounted on excavator boom to avoid vibration.
12. Bot the side grip and the bottom clamp jaws are identical to minimize inventory. Additional all **RoboVib** jaws have "**Kryptonite**" coating for exceptional wear life.
13. Three eccentrics are vertically stacked to minimize distance between driving force and pile center.
14. Commonly available elastomers isolate vibration from excavator. Extra elastomer mounting positions are provided so spring rate may be optimized for tough pile extraction applications.
15. Lockable adjusting nuts eliminate clearance in side grip arms to reduce vibration wear and insuring long life.
16. Commercial high pressure gear motor is interchangeable to exactly match excavator hydraulic flow to **RoboVib**. No flow controls or restrictions to cause damaging heat build up in excavator hydraulic system.
17. Gun drilled hydraulic distribution manifold is integral to suspesion yoke, to minimize plumbing and perfectly align hydraulic rotation swivel.
18. Replaceable offset bushings at the **RoboVib** excavator connection allow pin diameter and center distance changes to accommodate various brands and sizes of excavators.
19. Minimum width, fixed side clamp arm allows driving of "H" piles as small as 25cm.
20. All linkage and side grip arm pivot points are greaseable for long wear life.
21. Bottom clamp slider is chrome plated and greaseable via protected fitting. Gripping teeth are haredened for long life.
22. Lips on side grip arms allow "nested" sheet piles to be split for lifting access. Wide opening of side grip arms allows multiple piles to be clamped when unloading trucks.
23. Integral sling hook with safety latch facilitates lifting piles and other lifting.
24. Large bore hydraulic swivel provides 360° continuous rotation, with minimum flow restriction.
25. Wide side grip arms fabricated from high strength T-1 steel provide exceptional rigidity to transmit vibratory output force.
26. All hydraulic cylinders are designed for vibratory duty and include filled nylon bearings on the piston and piston rod for non abrasive guiding.